



Model FOSTC

RS-232, 422 or 485 Signals Up To 2.5 Miles with Fiber Optic Modem

Description

Fiber optic cabling has inherent resistance to EMI/RFI and transient immunity, making it ideal for industrial and utility data communication applications.

The FOSTC was designed to provide the most versatile connection possible between any asynchronous serial equipment using Fiber Optic cable. The FOSTC can be used for point-to-point communications between serial devices, or in a multi-drop fiber ring configuration, allowing multiple serial devices to communicate with each other.

It allows any two pieces of asynchronous serial equipment to communicate full or half-duplex over two fibers at typical distances up to 2.5 miles (4 km). To extend the distance of the fiber link beyond 2.5 miles, use B&B model FOSTDRP Fiber Optic Repeater.

Features/Applications

- Point-to-point or multi-drop ring configuration
- RS-232, RS-422, or RS-485 operation
- Use as a converter from RS-232 to RS-422/485
- RS-422/485 data rates up to 500 kbps
- RS-485 Automatic Send Data driver control
- Inherent EMI/RFI and transient immunity.
- Eliminate ground loops
- Extend serial signals up to 2.5 miles
- Uses popular ST type fiber connectors
- Standard DB25 female (DCE) for serial connections
- 12VDC powered (separate supply required)

Figure 1: Typical Setups

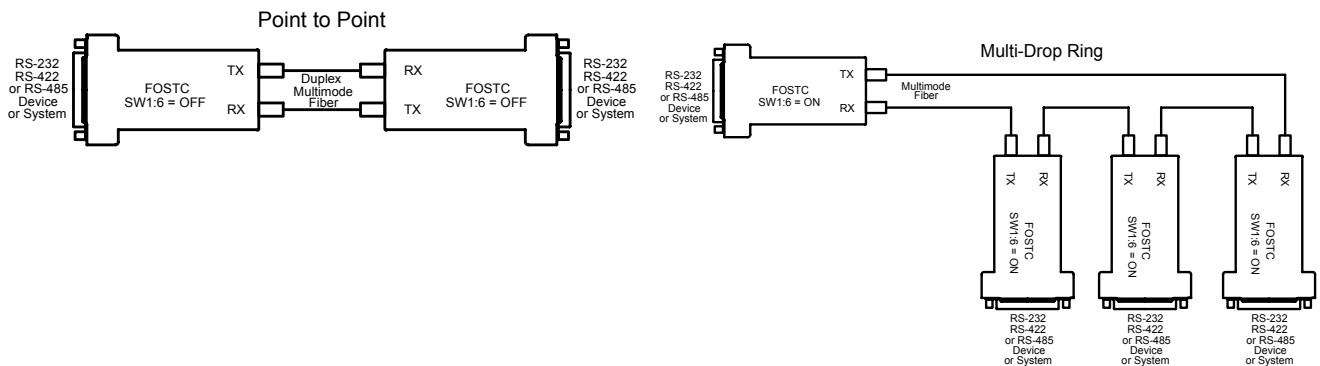

Fiber Optic Connections

The FOSTC uses a separate LED emitter and photo-detector operating at 820 nm wavelength. Connections to the emitter and detector are on ST type connectors. Almost any multimode glass fiber size can be used including 50/125 μm , 62.5/125 μm , 100/140 μm , and 200 μm . One fiber is required for each connection between a transmitter and receiver. In a point-to-point configuration, two fibers are required between the two modems, one for data in each direction. A multi-drop ring configuration requires one fiber between TX and RX around the loop. See Figure 1 for typical point-to-point and multi-drop configurations.

The most important consideration in planning the fiber optic link is the "power budget" of the fiber modem. This value represents the amount of loss in dB that can be present in the link between the two modems before the units fail to perform properly. This value includes line attenuation as well as connector loss. For the FOSTC the typical connector-

International Headquarters:

B&B Electronics Mfg. Co. 707 Dayton Road P.O. Box 1040 Ottawa, IL 61350 USA
815-433-5100 Fax 433-5104 www.bb-elec.com orders@bb-elec.com support@bb-elec.com

B&B Electronics Ltd Westlink Commercial Park Oranmore Co. Galway Ireland
+353 91 792444 Fax +353 91 792445 www.bb-europe.com orders@bb-elec.com support@bb-europe.com

to-connector power budget is 12.1 dB. Because 62.5/125 µm cable typically has a line attenuation of 3 dB per Km at 820 nm, the 12.1 dB power budget translates into 2.5 miles. This assumes no extra connectors or splices in the link. Each extra connection would typically add 0.5 dB of loss, reducing the possible distance by 166 m (547 ft.). The actual loss should be measured before assuming distances.

RS-232 Connections

Connection of the FOSTC is simple and straightforward. The DB25 female serial connector is used for connecting to either RS-232, RS-422 or RS-485. The RS-232 signals are pinned as a DCE device (input on Pin 2 and output on Pin 3). A straight through cable can be used from your DB25 port on any DTE device such as a PC or terminal. A standard 9 to 25-pin adapter can be used in cases where the serial port on the DTE device is a DB9. A null modem cable or adapter that swaps pins 2 and 3 is needed for connecting to modems or other DCE devices. See Figure 2 for connection diagrams to 9 pin and 25 pin DTE and DCE devices. Because RS-422 and RS-485 signals are also available on the same connector, take special care not to hook any external signals to these pins. This is not a problem for most serial devices, but a custom cable must be made that does not connect to the extra pins on the DB25 connector if your device has power or special non-standard outputs.

Figure 2: RS-232 Connection Diagrams

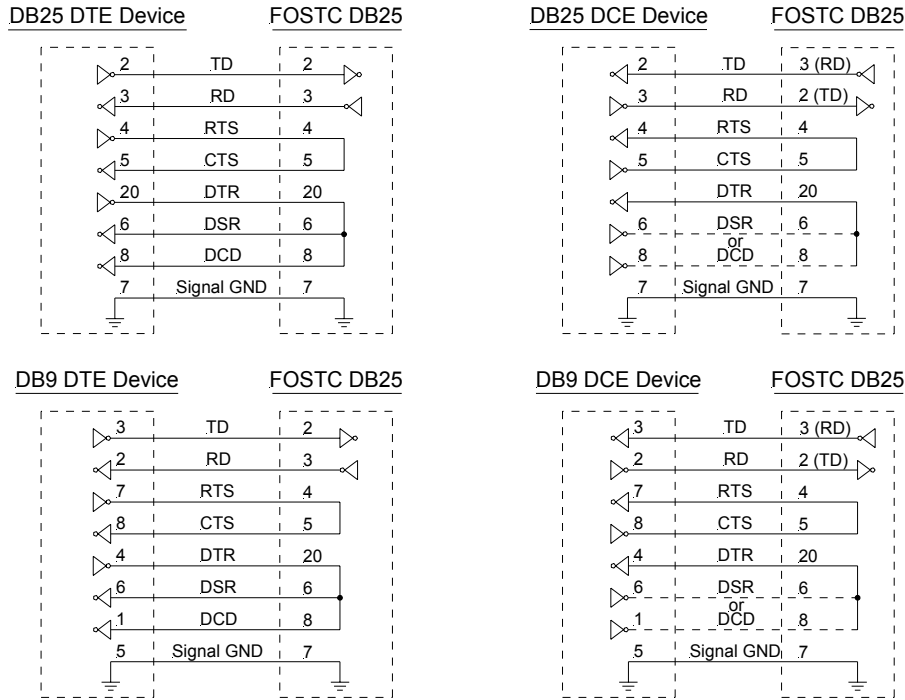

RS-422 & RS-485 Connections

The RS-422/485 driver and receiver are connected to 4 pins on the DB25 connector. Signal ground is on Pin 7. When connecting to a four-wire RS-422/485 device or system, connect the output of your device to pins 16 (B or +) and 17 (A or +). Connect the input to your device to pins 14 (B or +) and 15 (A or -). For two-wire RS-485 systems, the driver and receiver of the FOSTC must be connected together by tying pins 14 and 16 together and 15 and 17 together. This allows the FOSTC to communicate half-duplex over the same pair. Refer to Figure 3 for connection diagrams to your RS-422 or RS-485 equipment.

If termination is needed, a spot on the PCB of the FOSTC labeled Rt allows you to solder in a termination resistor across the RD(A) and RD(B) lines. Removing R8 and R16 and replacing them with through-hole components can also change the off-state bias resistor values. Before making modifications to the FOSTC, be sure to consult B&B Electronics' free RS-422/485 Application Note or other sources of information to see if termination is necessary. The Application Note is available from our Web site, or call and we will be happy to send you one at no charge.

International Headquarters:

B&B Electronics Mfg. Co. 707 Dayton Road P.O. Box 1040 Ottawa, IL 61350 USA
815-433-5100 Fax 433-5104 www.bb-elec.com orders@bb-elec.com support@bb-elec.com

B&B Electronics Ltd Westlink Commercial Park Oranmore Co. Galway Ireland
+353 91 792444 Fax +353 91 792445 www.bb-europe.com orders@bb-elec.com support@bb-europe.com

Figure 3: RS-422/485 Connection Diagrams

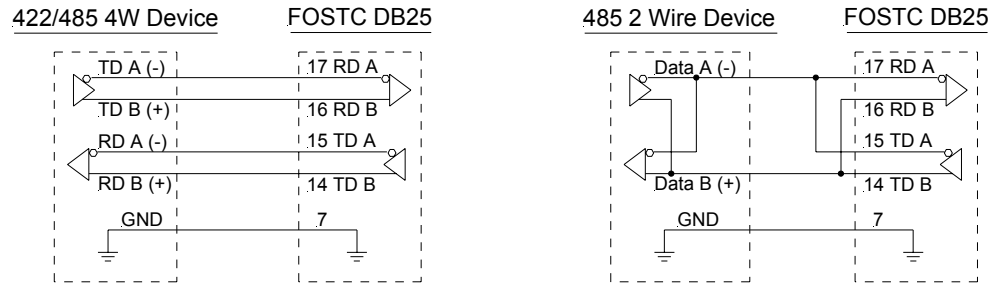

Dip-Switch Setup

The Dip-Switch (SW1) on the FOSTC defines the mode of operation when being used for RS-422 or RS-485. Positions 1 through 5 on the switch determine the timeout of the RS-485 driver. Because the driver is controlled by hardware, a specific time must be set to tell the hardware how long to wait for data on the fiber side before turning off the RS-422/485 driver. If this time is set too short, the driver could be disabled before transmission is complete, resulting in data corruption. If the time is set too long, the RS-485 device may respond before the RS-422/485 driver in the FOSTC is disabled, corrupting this response. We recommend that the timeout be set for approximately one character time or longer. The character times for several different baud rates are selectable on switch positions 1 through 5. If you need a different timeout than what is provided, R10 can be removed and replaced with a different value R9. Table 1 shows different timeout values for the switch positions as well as typical R9 replacement values.

Table 1: RS-485 Timeout Selection

Baud Rate	Pos. 1	Pos. 2	Pos. 3	Pos. 4	Pos. 5	R9	Time(ms)
1200	ON	OFF	OFF	OFF	OFF	820 KΩ	8.20
2400	ON	OFF	OFF	OFF	OFF	430 KΩ	4.30
4800	OFF	OFF	OFF	OFF	ON	Not Used	2.20
9600	OFF	OFF	OFF	ON	OFF	Not Used	1.30
19.2K	OFF	OFF	ON	OFF	OFF	Not Used	0.56
38.4K	OFF	ON	OFF	OFF	OFF	Not Used	0.27
57.6K	ON	OFF	OFF	OFF	OFF	Not Used	0.22
76.8K	ON	OFF	ON	ON	OFF	Not Used	0.14
115.2K	ON	ON	ON	OFF	OFF	Not Used	0.10
153.6K	ON	OFF	OFF	OFF	OFF	6.2 KΩ	0.06
230.4K	ON	OFF	OFF	OFF	OFF	4.3 KΩ	0.04
460.8K	ON	OFF	OFF	OFF	OFF	2.2 KΩ	0.02

Position 6 of SW1 sets the unit in a “Multidrop” mode or a “Point-to-Point” mode. When the FOSTC is set in a “Multidrop” mode, data arriving on the Fiber Optic receiver is repeated back out the transmitter. When set in a “Point-to-Point” mode, data arriving at the Fiber optic receiver is not sent back out the Fiber Optic transmitter. Position 6 must be turned “On” when the FOSTC is to be used in a multi-drop ring configuration. It must be turned “Off” when the FOSTC is to be used as either end of a point-to-point communication line. See Figure 3 for typical system setups using the FOSTC in its different modes.

Positions 7 and 8 of SW1 determine when the RS-422/485 driver and receiver are enabled. Position 7 controls the driver and Position 8 controls the receiver. For RS-422 operation, set both switches to the “Off” position. For multi-drop RS-485 four-wire systems, position 7 should be “On” and position 8 should be “Off.” This allows the receiver to be enabled all of the time and eliminates some possible timing problems. For RS-485 two-wire systems, both switches should be in the “On” position. This disables the RS-422/485 receiver whenever the driver is enabled, preventing data from being echoed back to the fiber side of the FOSTC.

Table 2: 422/485 Switch Settings

	Position 7 TX Enable	Position 8 RX Enable
RS-485 2-Wire Mode (half duplex)	ON	ON
RS-485 4-Wire Mode (full duplex)	ON	OFF
RS-422 Mode (full duplex)	OFF	OFF

Table 2 illustrates the switch settings for typical setups.

International Headquarters:

B&B Electronics Mfg. Co. 707 Dayton Road P.O. Box 1040 Ottawa, IL 61350 USA
815-433-5100 Fax 433-5104 www.bb-elec.com orders@bb-elec.com support@bb-elec.com

B&B Electronics Ltd Westlink Commercial Park Oranmore Co. Galway Ireland
+353 91 792444 Fax +353 91 792445 www.bb-europe.com orders@bb-elec.com support@bb-europe.com

Multi-Drop Operation

A multi-drop configuration is created by forming a ring of FOSTCs (see Figure 1). Whichever serial device sends data, all other devices receive it. The data is repeated around the fiber ring until it reaches the source, where it is blocked. There is no echo back to the serial side of the sending device. Each fiber transmitter must be connected to the following converter's receiver. Set SW1:6 to the "On" position on all FOSTCs in the ring. Any device can be full-duplex (RS-232, RS-422, or four-wire RS-485), or half duplex RS-485. Because all data shares the same path on the ring, only one device can send data at a time.

Interfacing to Fiber Devices from Other Manufacturers

Note: The factory default for the LED emitter is to have the light ON in the idle state. To interconnect with other devices that have the light OFF in the idle state, this unit would need to be modified. To modify the unit so that the light is OFF in the idle state, contact B&B Electronics Technical Support.

Typical Installation Configuration

Below is a University Campus setup that illustrates the basic configuration of a typical Fiber Optic Network. This scenario uses a combination of B&B Fiber devices including 3 of the FOSTCs, 2 of the fiber repeaters FOSTDRP, and one of the DIN Rail mount Fiber Converters FOSTCDR. Each of the items requires a power supply (not shown).

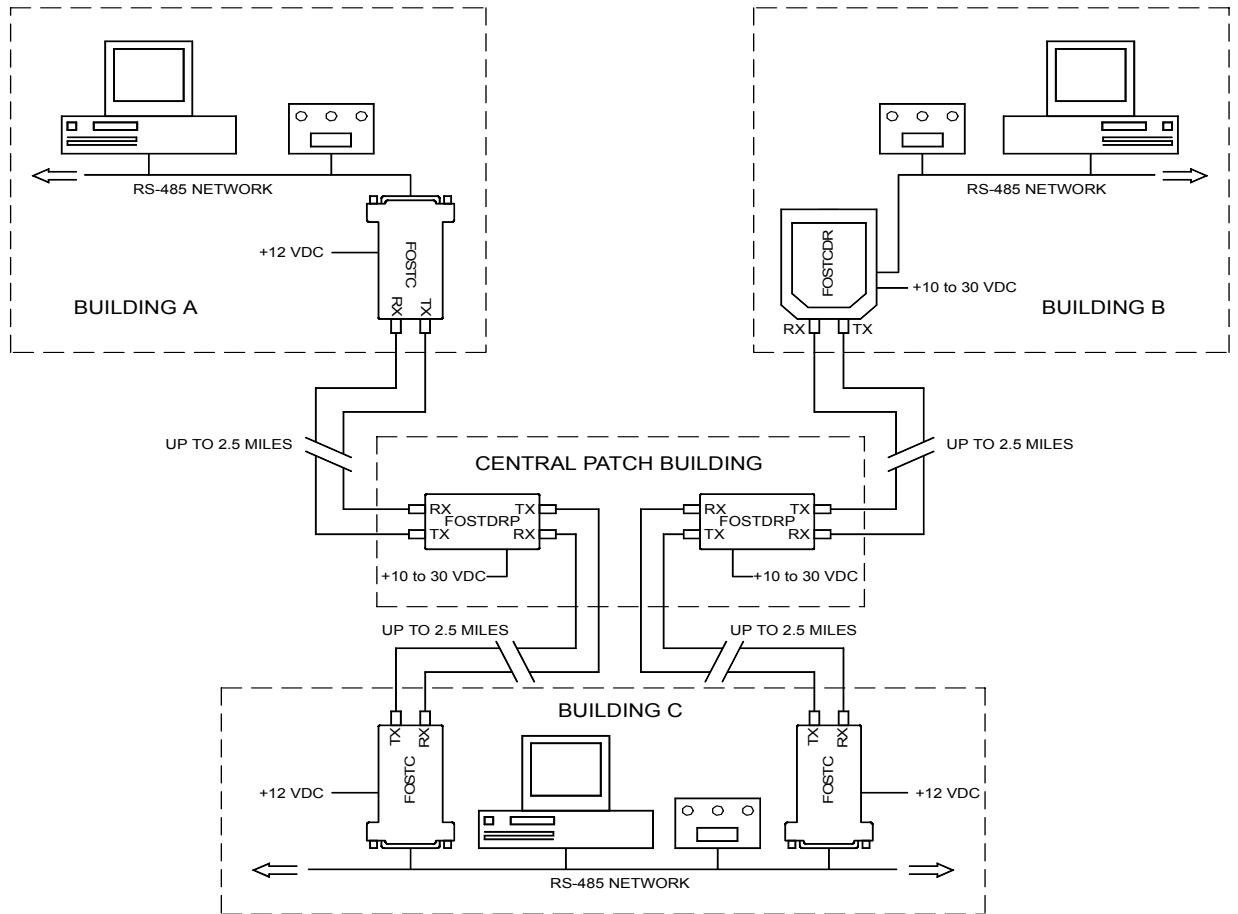

Figure 4. Typical Campus Setup

International Headquarters:

B&B Electronics Mfg. Co. 707 Dayton Road P.O. Box 1040 Ottawa, IL 61350 USA
815-433-5100 Fax 433-5104 www.bb-elec.com orders@bb-elec.com support@bb-elec.com

B&B Electronics Ltd Westlink Commercial Park Oranmore Co. Galway Ireland
+353 91 792444 Fax +353 91 792445 www.bb-europe.com orders@bb-elec.com support@bb-europe.com

Specifications/Features

Transmission Line: Dual multimode optical cable
 Point-to-Point Transmission: Asynchronous, half or full-duplex
 Multi-Drop Transmission: Asynchronous, half duplex fiber ring
 Interfaces: RS-232, RS-422, or RS-485
 Connectors: DB25 female for serial connection, ST connectors for fiber
 Dimensions: 4.3 x 2.3 x 0.95 in (11 x 5.9 x 2.5 cm)
 Power Supply Connections: 2.5mm phone jack (Tip Positive) or DB25 pins 25(+) & 12(-)
 Recommended Power Supply: B&B Model# 232PS3

All specifications given using 62.5/125µm glass multi-mode fiber.

Parameter	Min.	Typical	Max.	Conditions
Data Rates (RS-232 Operation)	0 bps		115.2 kbps	
Data Rates (RS-422/485 Operation)	0 bps		500 kbps	
Power Supply Voltage	10 VDC	12 VDC	14 VDC	
Power Supply Current Draw			140 mA	Full RS-485 Termination
Optic Wavelength		820 nm		
Fiber TX Launch Power	-17 dBm	-13 dBm	-10 dBm	
Minimum Required Fiber Rx Power		-25.4 dBm	-24 dBm	
Maximum Receiver Power			-10 dBm	
Coupled Power Budget		12.1 dB		
Fiber Range		2.5 Miles		
End to End Delay		2000 ns	2650 ns	Point to Point RS-232 Operation (See Notes 1 & 2)
End to End Delay		550 ns	1000 ns	Point to Point RS-422/485 Operation (See Notes 1 & 2)
End to End Skew		900 ns	1100 ns	Point to Point RS-232 Operation (See Note 3)
End to End Skew		50 ns	120 ns	Point to Point RS-422/485 Operation (See Note 3)
Maximum Total Fiber Ring Length			5 Miles	(See Note 1)
Delay between Rx & Tx on a fiber ring	52 µs			(See Note 4)

Note 1: For the total transmission time over long fibers, the time to transverse the fiber must be considered if delay is an issue. Light takes about 8.05 microseconds to travel over 1 mile of fiber.

Note 2: When operating in a ring configuration, each node in addition to the two in the point-to-point specification adds an additional 100 to 200 nanoseconds of delay.

Note 3: When operating in a ring configuration, each node in addition to the two in the point-to-point specification adds an additional 50 to 70 nanoseconds of skew.

Note 4: When operating in a ring configuration, each serial device must wait at least this minimum time between receiving data from the ring and transmitting back on to it.

Recommended Maximum FOSTCs in a Fiber Ring Topology.

Baud Rate	RS-232 Operation	RS-422/485 Operation
460.8 kbps	N/A	2
230.4 kbps	N/A	4
115.2 kbps	2	8
57.6 kbps	8	16
38.4 kbps	16	24
19.2 kbps and lower	32	32

International Headquarters:

B&B Electronics Mfg. Co. 707 Dayton Road P.O. Box 1040 Ottawa, IL 61350 USA
 815-433-5100 Fax 433-5104 www.bb-elec.com orders@bb-elec.com support@bb-elec.com

B&B Electronics Ltd Westlink Commercial Park Oranmore Co. Galway Ireland
 +353 91 792444 Fax +353 91 792445 www.bb-europe.com orders@bb-elec.com support@bb-europe.com

Figure 5: FOSTC Circuit Diagram

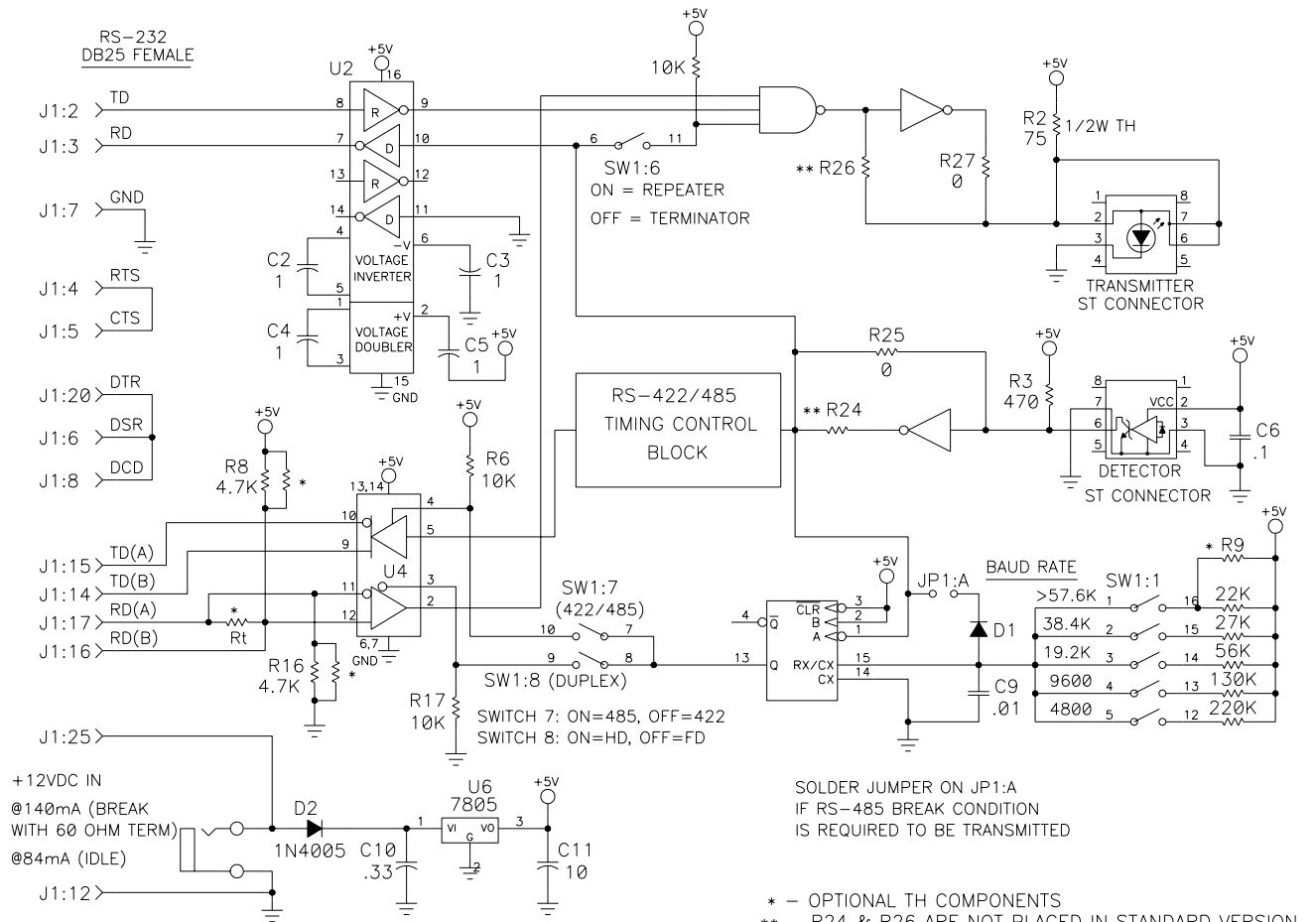

SOLDER JUMPER ON JP1:A
IF RS-485 BREAK CONDITION
IS REQUIRED TO BE TRANSMITTED

- * - OPTIONAL TH COMPONENTS
- ** - R24 & R26 ARE NOT PLACED IN STANDARD VERSION.
R24 AND R26 ARE USED TO INVERT THE FIBER SIGNAL.
REMOVE R25 AND R27 WHEN R24 AND R26 ARE PLACED.

DECLARATION OF CONFORMITY

Manufacturer's Name: B&B Electronics Manufacturing Company
 Manufacturer's Address: P.O. Box 1040
 707 Dayton Road
 Ottawa, IL 61350 USA
 Model Number: FOSTC
 Description: High-Speed Fiber Optic Modem
 Type: Light industrial ITE equipment
 Application of Council Directive: 89/336/EEC
 Standards: EN 55022
 EN 61000-6-1
 EN 61000 (-4-2, -4-3, -4-4, -4-5, -4-6, -4-8, -4-11)

William H. Franklin III
 William H. Franklin III, Director of Engineering



International Headquarters:

B&B Electronics Mfg. Co. 707 Dayton Road P.O. Box 1040 Ottawa, IL 61350 USA
 815-433-5100 Fax 433-5104 www.bb-elec.com orders@bb-elec.com support@bb-elec.com

B&B Electronics Ltd Westlink Commercial Park Oranmore Co. Galway Ireland
 +353 91 792444 Fax +353 91 792445 www.bb-europe.com orders@bb-elec.com support@bb-europe.com